

ITENS FORNECIDOS:

A Paraf. 3,5x14
CP FC ZB

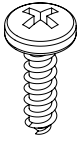

B Paraf. 3,5x14
CC FC ZB

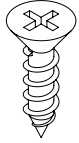

C Paraf. MQ PN
FC M 4x8 ZB
QPC48

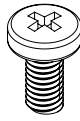

D Mc 20 Suporte
para fixação de
corredeira

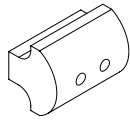

E Arruela 3/16
Cinza



INFORMAÇÕES

GERAIS:

NÍVEL DE
DIFICULDADE:
Fácil

QUANTIDADE DE
PESSOAS:
Uma



INSTRUMENTOS
NECESSÁRIOS:
Parafusadeira, chave
Phillips, itens fornecidos.

DICAS DE CONSERVAÇÃO:

Utilize um pano umedecido e
sabão neutro para a limpeza.

PRAZO DE GARANTIA:

Peças aço inox - 05 (cinco) anos
Peças cromadas - 01 (um) anos

1 Desmontar a corredeira como mostra o detalhe.

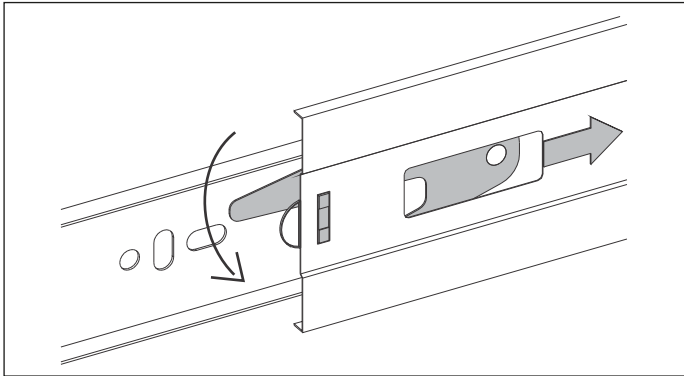

2 Prender com a ferragem a parte externa das corredeiras nas laterais do móvel.

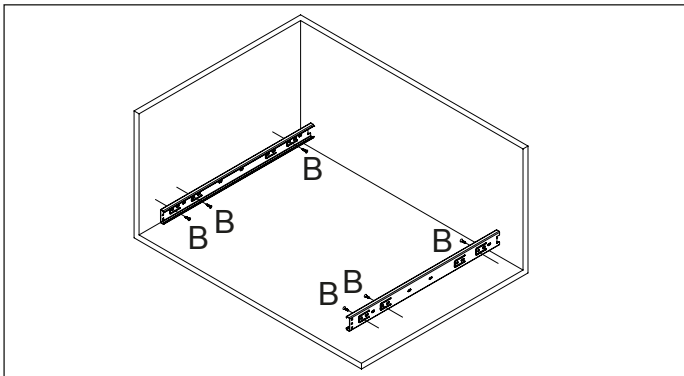

Prender a parte externa da corredeira, utilizando somente a **ferragem B** em módulos com **laterais de 18mm**, e utilizando as **ferragens B e E** em módulos com **laterais de 15mm**.

LATERAIS 15mm

LATERAIS 18mm

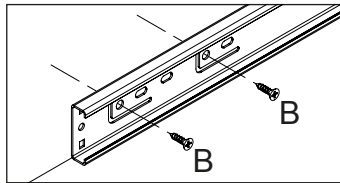
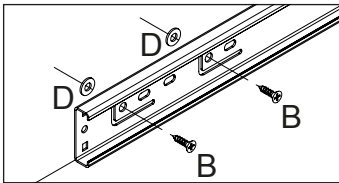

3 Posicionar o sistema de fixação frontal com o parafuso C.

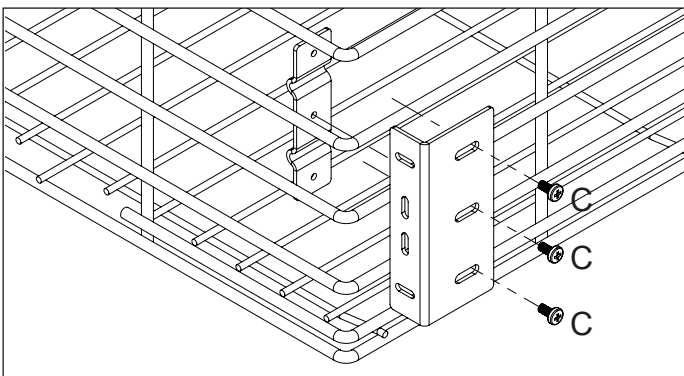

4 Fixar a parte interna da corredeira com a ferragem B e D como mostra o desenho.

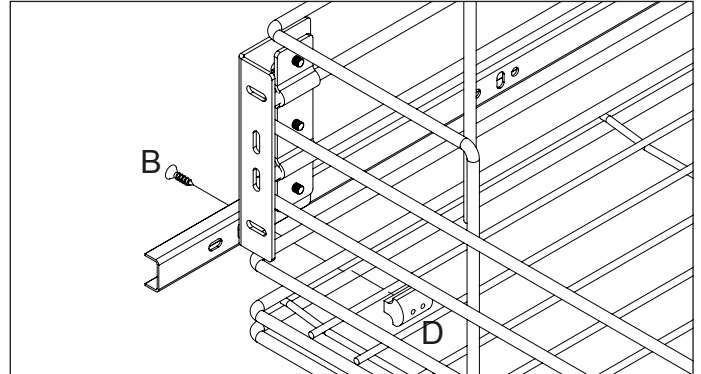

5 Conectar a gaveta ao tampo do móvel com a ferragem A, observando o alinhamento do mesmo no móvel.

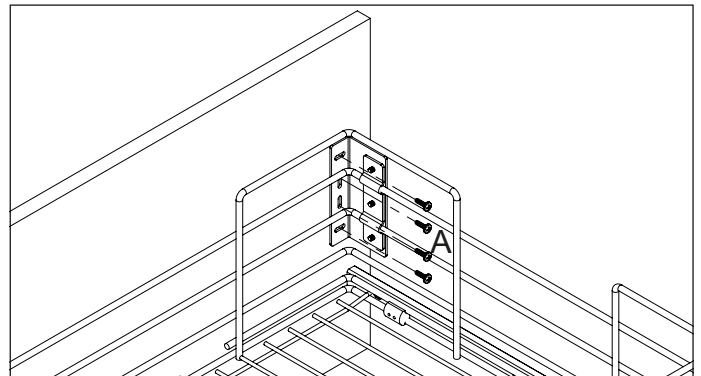

6 Introduzir a gaveta no módulo.

